

80V, 285A, 1.4mΩ N-channel Power SGT MOSFET
JMSH0802MTL
Features

- Excellent $R_{DS(ON)}$ and Low Gate Charge
- 100% UIS TESTED
- 100% ΔV_{ds} TESTED
- Halogen-free; RoHS-compliant
- Pb-free plating

Applications

- Load Switch
- PWM Application
- Power Management

Product Summary

Parameters	Value	Unit
V_{DSS}	80	V
$V_{GS(th)_{Typ}}$	2.9	V
$I_D(@V_{GS}=10V)$	285	A
$R_{DS(ON)_{Typ}}(@V_{GS}=10V)$	1.4	mΩ

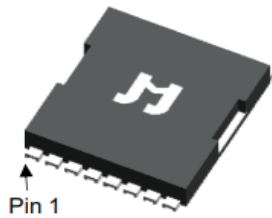
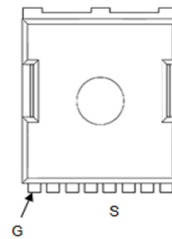
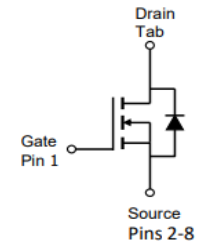
PowerJE@10x12 Top View

Pin Assignment

Schematic Diagram
Ordering Information

Device	Marking	MSL	Form	Package	Reel(pcs)	Per Carton (pcs)
JMSH0802MTL	SH0802M	1	Tape&Reel	PowerJE@10x12	2000	10000

Absolute Maximum Ratings (@ $T_C = 25^\circ\text{C}$ unless otherwise specified)

Symbol	Parameter	Value	Unit
V_{DS}	Drain-to-Source Voltage	80	V
V_{GS}	Gate-to-Source Voltage	± 20	V
I_D	Continuous Drain Current	$T_C = 25^\circ\text{C}$	285
		$T_C = 100^\circ\text{C}$	202
I_{DM}	Pulsed Drain Current ⁽¹⁾	Refer to Fig.4	A
E_{AS}	Single Pulsed Avalanche Energy ⁽²⁾	1423	mJ
P_D	Power Dissipation	$T_C = 25^\circ\text{C}$	310
		$T_C = 100^\circ\text{C}$	124
T_J, T_{STG}	Junction & Storage Temperature Range	-55 to 150	$^\circ\text{C}$

Thermal Characteristics

Symbol	Parameter	Max	Unit
$R_{\theta JA}$	Thermal Resistance, Junction to Ambient ⁽³⁾	34	$^\circ\text{C}/\text{W}$
$R_{\theta JC}$	Thermal Resistance, Junction to Case	0.4	

**Electrical Characteristics** ($T_J = 25^\circ\text{C}$ unless otherwise specified)

Symbol	Parameter	Conditions	Min.	Typ.	Max.	Unit
Off Characteristics						
$V_{(BR)DSS}$	Drain-Source Breakdown Voltage	$I_D = 250\mu\text{A}$, $V_{GS} = 0\text{V}$	80	-	-	V
I_{DSS}	Zero Gate Voltage Drain Current	$V_{DS} = 64\text{V}$, $V_{GS} = 0\text{V}$	-	-	1.0	μA
I_{GSS}	Gate-Body Leakage Current	$V_{DS} = 0\text{V}$, $V_{GS} = \pm 20\text{V}$	-	-	± 100	nA
On Characteristics						
$V_{GS(th)}$	Gate Threshold Voltage	$V_{DS} = V_{GS}$, $I_D = 250\mu\text{A}$	2.0	2.9	3.8	V
$R_{DS(ON)}$	Static Drain-Source ON-Resistance ⁽⁴⁾	$V_{GS} = 10\text{V}$, $I_D = 20\text{A}$	-	1.4	2.0	m Ω
Dynamic Characteristics						
R_g	Gate Resistance	$f = 1\text{MHz}$	-	0.4	-	Ω
C_{iss}	Input Capacitance	$V_{GS} = 0\text{V}$, $V_{DS} = 40\text{V}$, $f = 1\text{MHz}$	6243	8740	11799	pF
C_{oss}	Output Capacitance		1257	1760	2376	pF
C_{rss}	Reverse Transfer Capacitance		19	26	35	pF
Q_g	Total Gate Charge	$V_{GS} = 0$ to 10V $V_{DS} = 40\text{V}$, $I_D = 20\text{A}$	91	128	173	nC
Q_{gs}	Gate Source Charge		29	40	54	nC
Q_{gd}	Gate Drain ("Miller") Charge		18	26	34	nC
Switching Characteristics						
$t_{d(on)}$	Turn-On DelayTime	$V_{GS} = 10\text{V}$, $V_{DD} = 39\text{V}$ $I_D = 20\text{A}$, $R_{GEN} = 6.2\Omega$	-	36	-	ns
t_r	Turn-On Rise Time		-	38	-	ns
$t_{d(off)}$	Turn-Off DelayTime		-	87	-	ns
t_f	Turn-Off Fall Time		-	43	-	ns
Body Diode Characteristics						
I_S	Maximum Continuous Body Diode Forward Current		-	-	285	A
I_{SM}	Maximum Pulsed Body Diode Forward Current		-	-	1140	A
V_{SD}	Body Diode Forward Voltage	$V_{GS} = 0\text{V}$, $I_S = 20\text{A}$	-		1.2	V
t_{rr}	Body Diode Reverse Recovery Time	$I_F = 20\text{A}$, $di/dt = 100\text{A}/\mu\text{s}$	94	127	178	ns
Q_{rr}	Body Diode Reverse Recovery Charge		-	194	-	nC

- Notes:
1. Repetitive Rating: Pulse Width Limited by Maximum Junction Temperature.
 2. E_{AS} condition: Starting $T_J = 25^\circ\text{C}$, $V_{DD} = 40\text{V}$, $V_G = 10\text{V}$, $R_G = 25\text{ohm}$, $L = 3\text{mH}$, $I_{AS} = 30.8\text{A}$, $V_{DD} = 0\text{V}$ during time in avalanche.
 3. $R_{\theta JA}$ is measured with the device mounted on a 1inch^2 pad of 2oz copper FR4 PCB.
 4. Pulse Test: Pulse Width $\leq 300\mu\text{s}$, Duty Cycle $\leq 0.5\%$.



Typical Performance Characteristics

Figure 1: Power De-rating

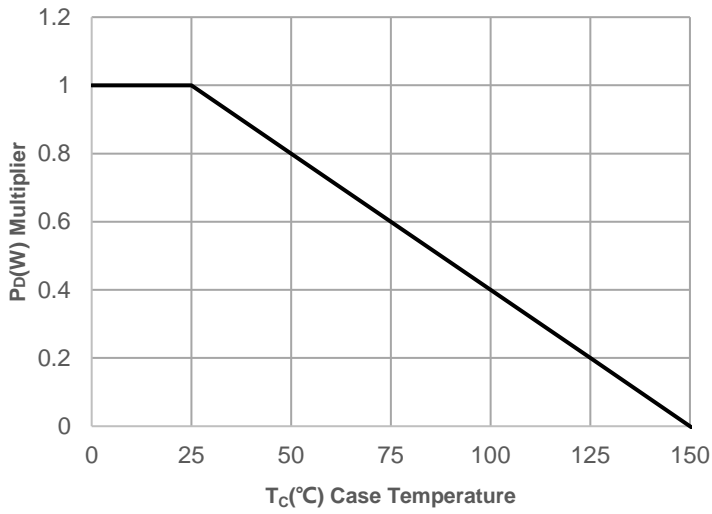

Figure 2: Current De-rating

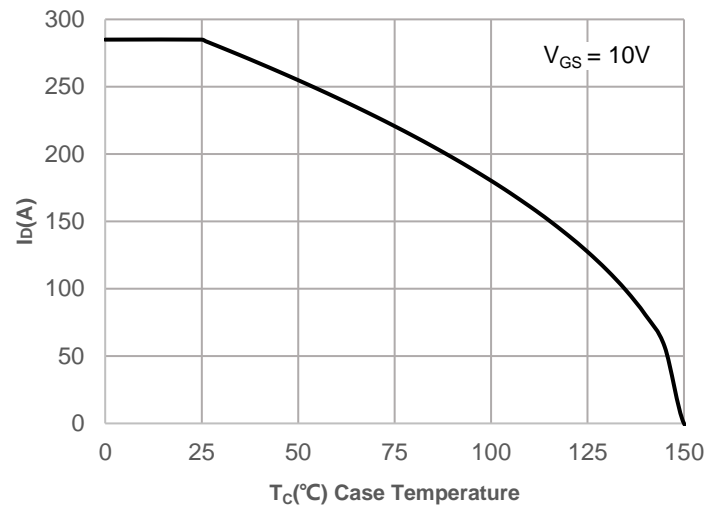

Figure 3: Normalized Maximum Transient Thermal Impedance

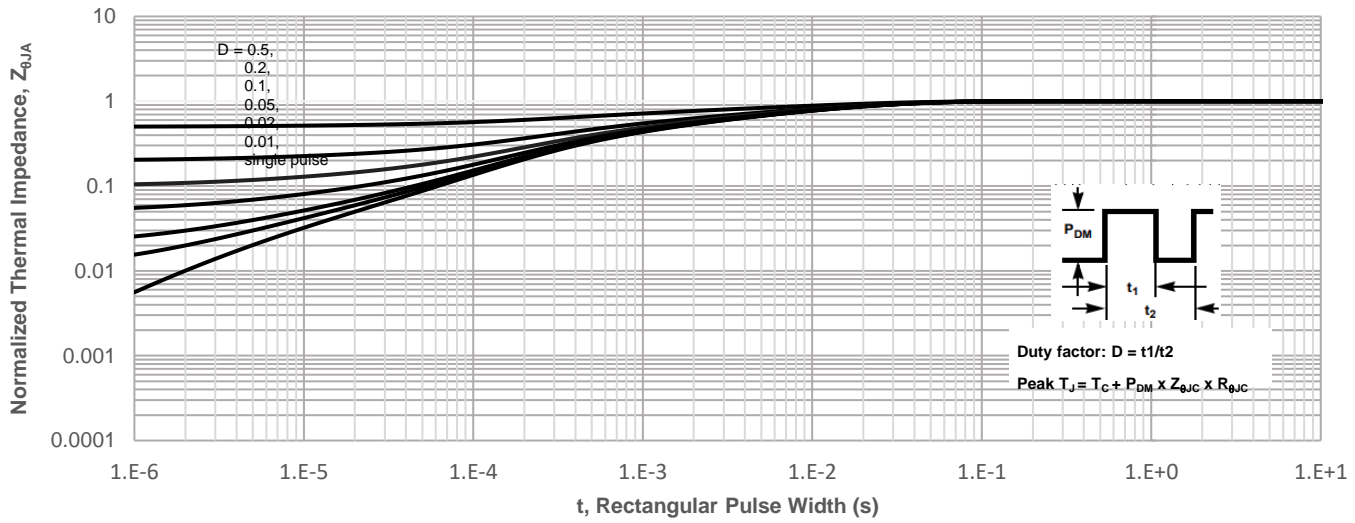
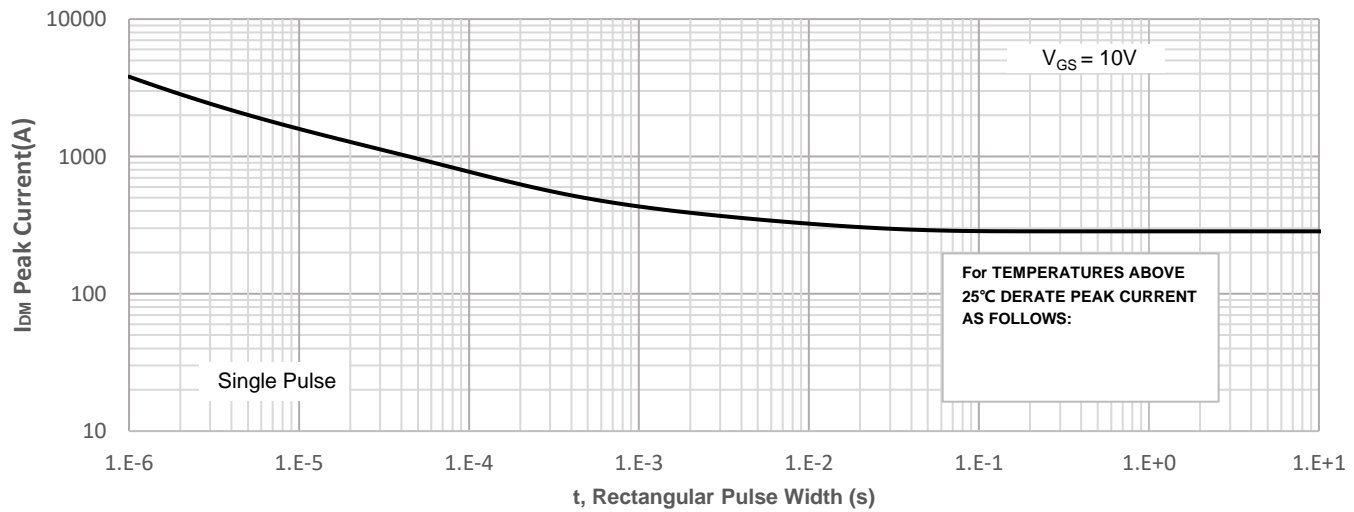

Figure 4: Peak Current Capacity



Typical Performance Characteristics

Figure 5: Output Characteristics

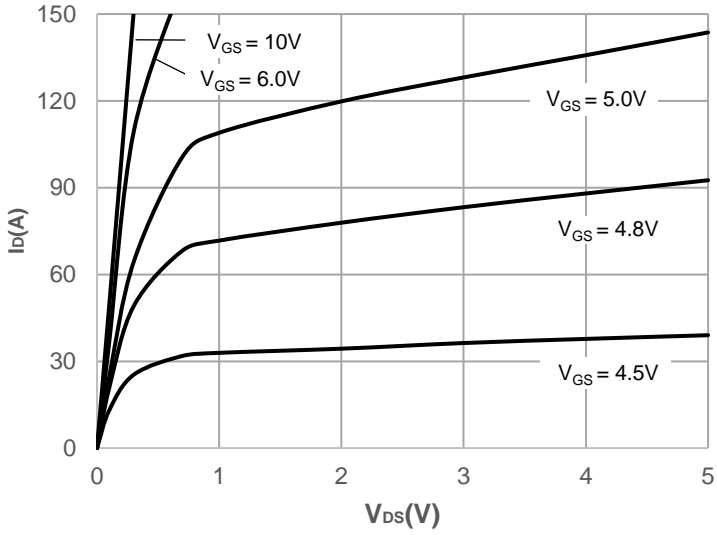

Figure 6: Typical Transfer Characteristics

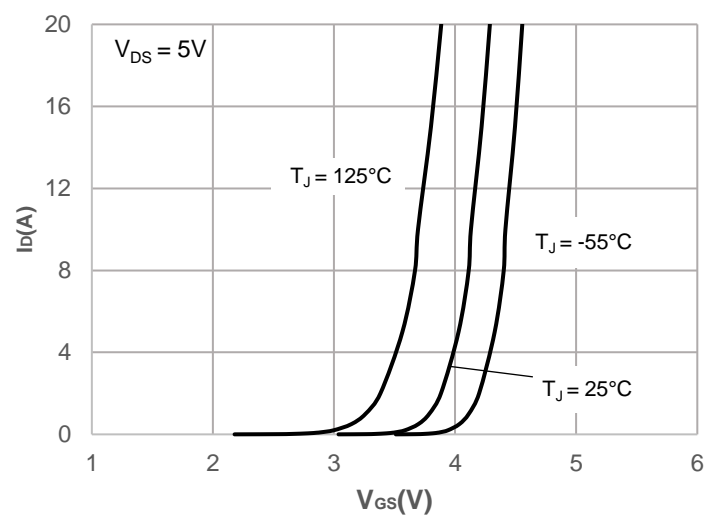

Figure 7: On-resistance vs. Drain Current

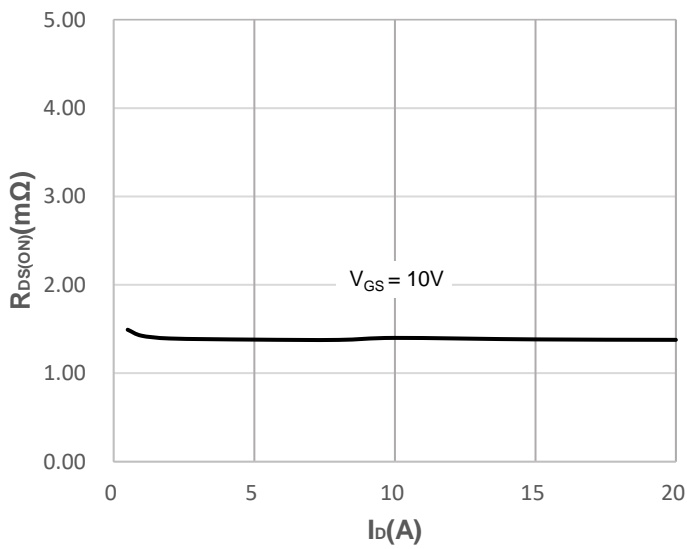

Figure 8: Body Diode Characteristics

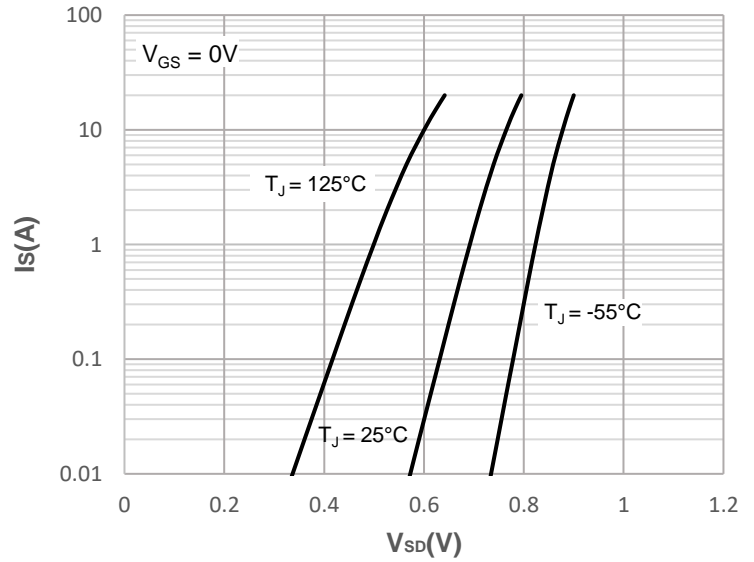

Figure 9: Gate Charge Characteristics

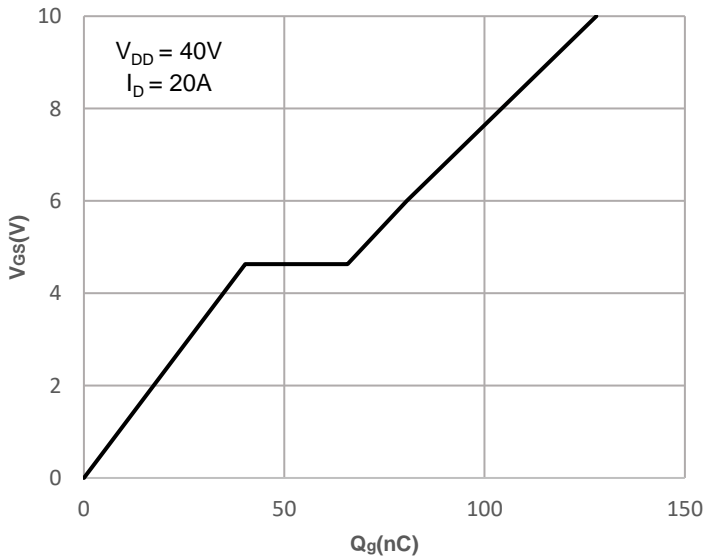
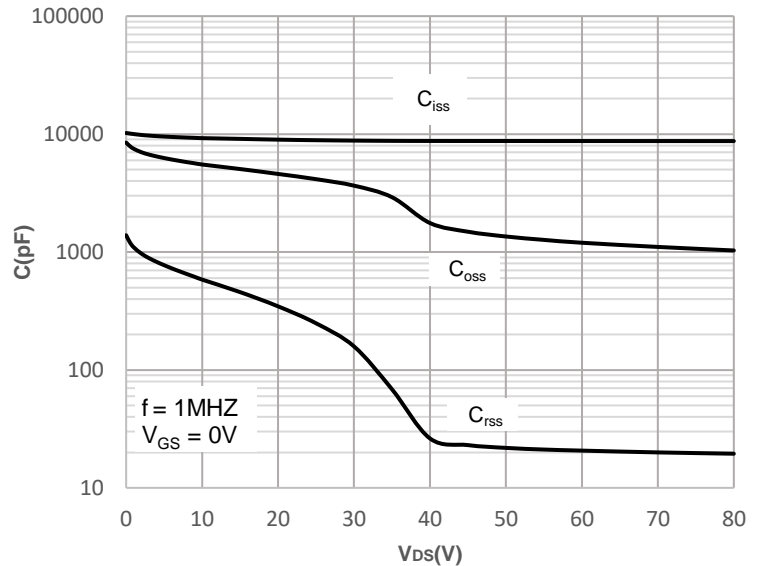

Figure 10: Capacitance Characteristics



Typical Performance Characteristics

Figure 11: Normalized Breakdown voltage vs. Junction Temperature

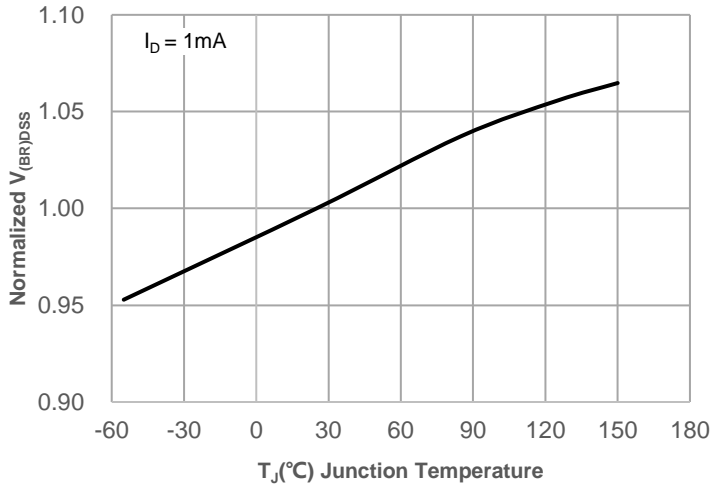

Figure 12: Normalized on Resistance vs. Junction Temperature

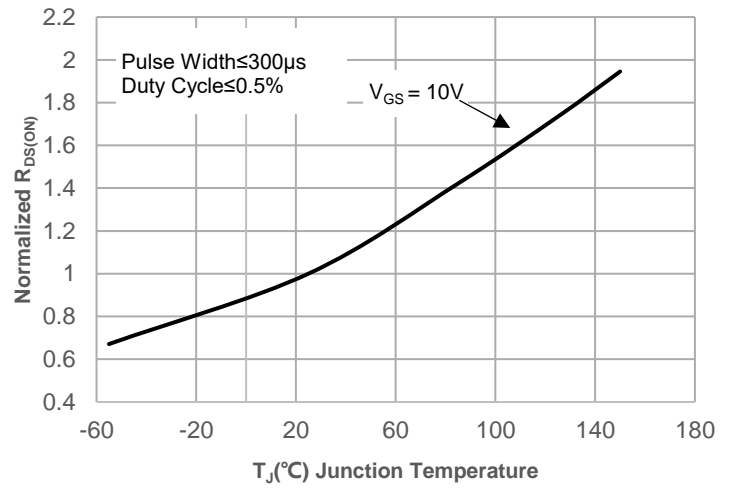

Figure 13: Normalized Threshold Voltage vs. Junction Temperature

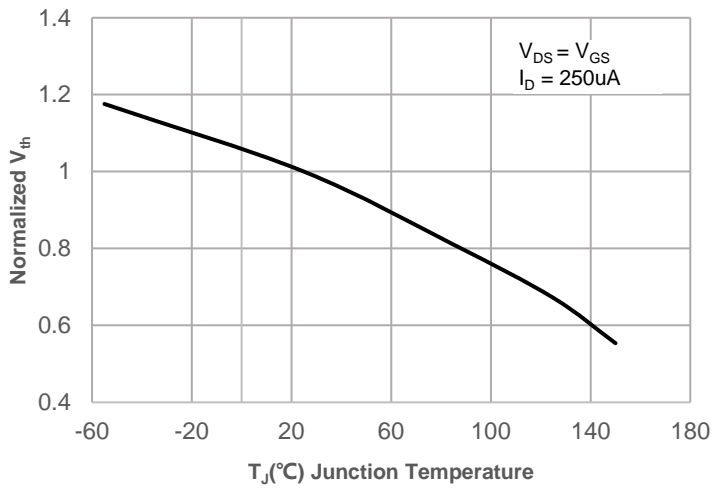

Figure 14: $R_{DS(ON)}$ vs. V_{GS}

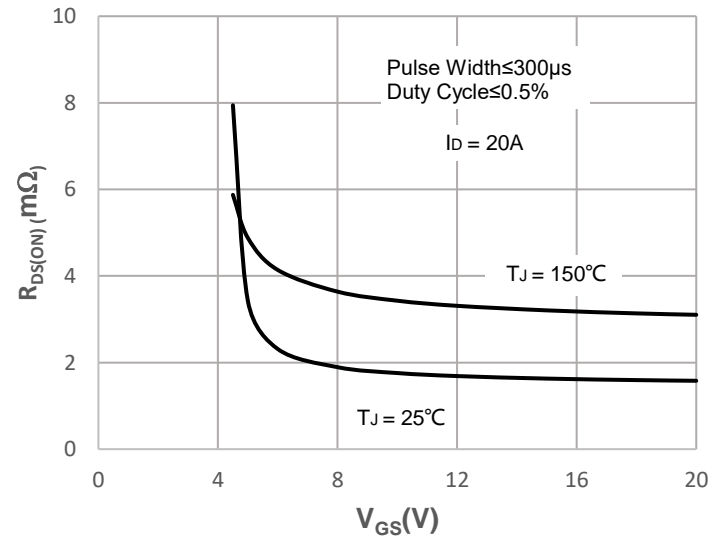
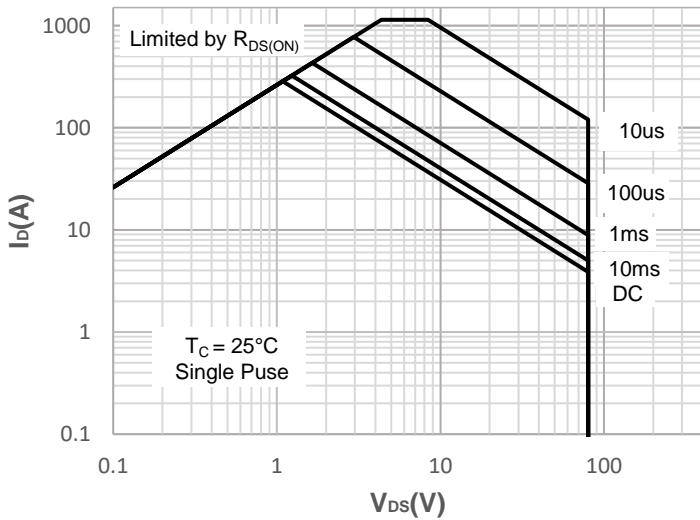

Figure 15: Maximum Safe Operating Area



Test Circuit



Figure 1: Gate Charge Test Circuit & Waveform

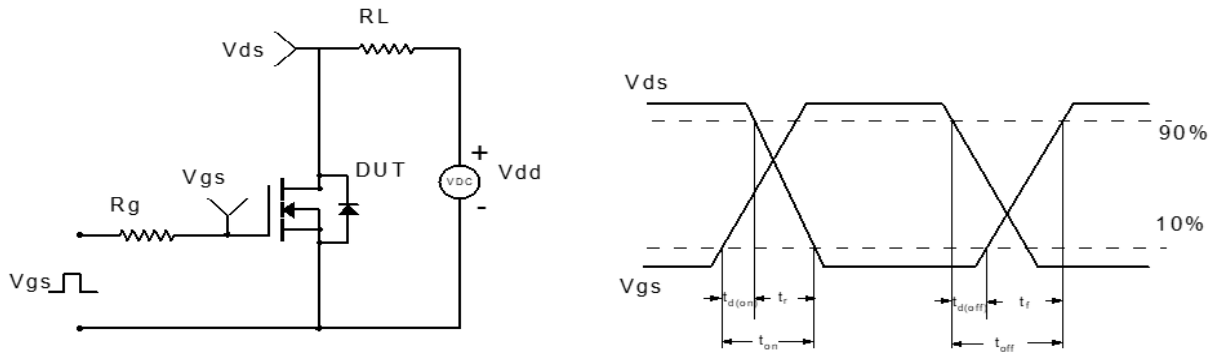

Figure 2: Resistive Switching Test Circuit & Waveform

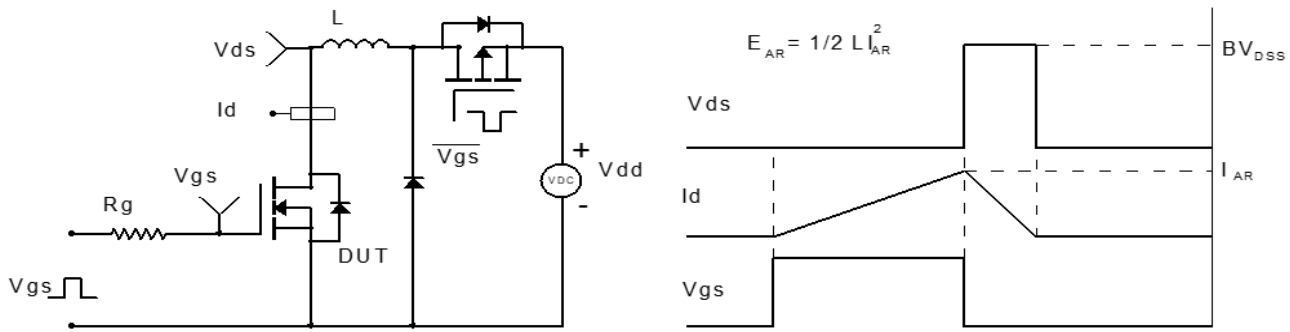

Figure 3: Unclamped Inductive Switching Test Circuit & Waveform

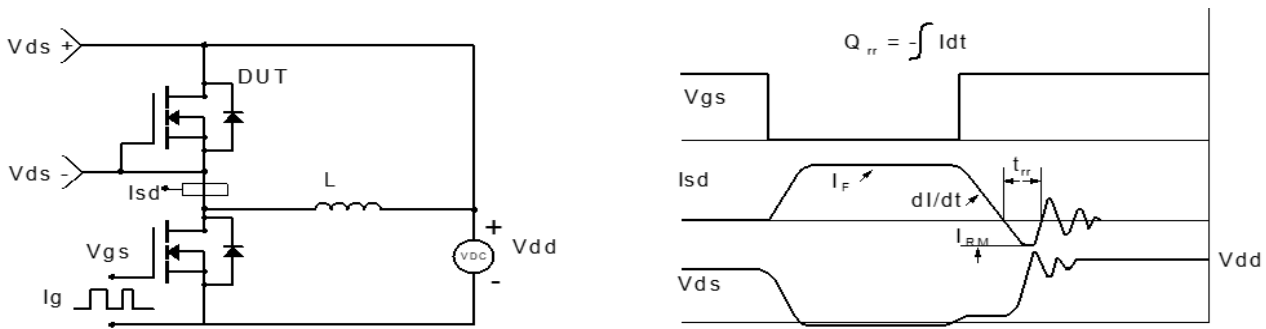
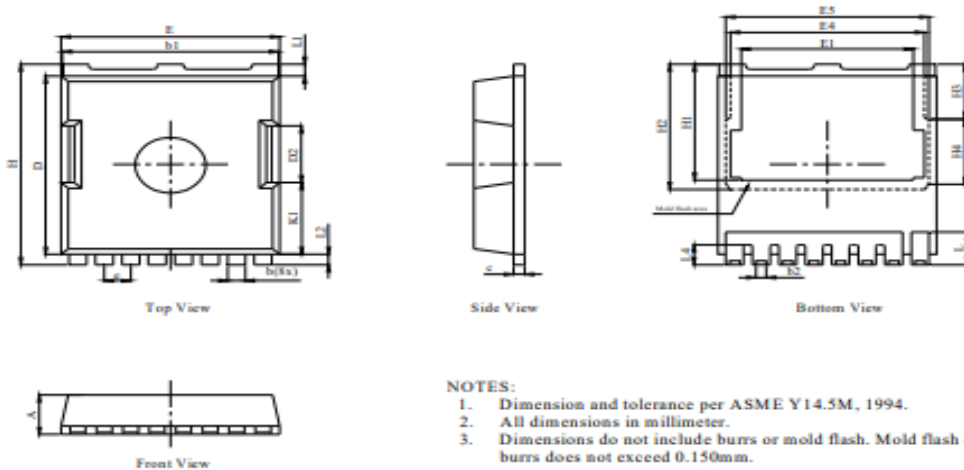

Figure 4: Diode Recovery Test Circuit & Waveform



Package Mechanical Data(PowerJE®10x12)

Package Outlines



- NOTES:
1. Dimension and tolerance per ASME Y14.5M, 1994.
 2. All dimensions in millimeter.
 3. Dimensions do not include burrs or mold flash. Mold flash or burrs does not exceed 0.150mm.

DIM.	MILLIMETER		
	MIN.	NOM.	MAX.
A	2.20	2.30	2.40
b	0.70	0.80	0.90
b1	9.70	9.80	9.90
b2	0.42	0.46	0.50
c	0.40	0.50	0.60
D	10.28	10.38	10.58
D2		3.30	
E	9.70	9.90	10.10
E1		7.80	
E4		8.80	
E5		9.20	
e		1.20 (BSC)	
H	11.48	11.68	11.88
H1	6.55	6.75	6.85
H2		7.30	
H3		3.20	
H4		3.80	
K1		4.18	
L	1.70	1.90	2.10
L1		0.70	
L2		0.60	
L4	1.00	1.15	1.30

Recommended Soldering Footprint

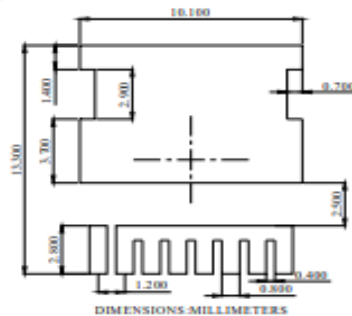

Information furnished in this document is believed to be accurate and reliable. However, Jiangsu JieJie Microelectronics Co.,Ltd assumes no responsibility for the consequences of use without consideration for such information nor use beyond it. Information mentioned in this document is subject to change without notice, apart from that when an agreement is signed, Jiangsu JieJie complies with the agreement. Products and information provided in this document have no infringement of patents. Jiangsu JieJie assumes no responsibility for any infringement of other rights of third parties which may result from the use of such products and information.

is a registered trademark of Jiangsu JieJie Microelectronics Co.,Ltd.

